

SSS-903 GAS DETECTOR

ESP model SSS Gas Detector of hydrogen sulphide, combustible and toxic gases is intended for automatic and continuous monitoring of flammable, toxic and combustible gas levels. SSS consist of Transmitter SSS (threshold device) and plug-in universal gas transducers PGU with electrochemical (PGU-E), infrared (PGU-IR) and photoionized (PGU-P) sensors.

Transmitter SSS is the universal one-channel threshold unit intended for visualization of gas signals values receiving from plug-in gas transducers. Transmitter SSS has following output signals: 3 threshold relays and 1 "fault" relay, digital output (RS-485) and analog output 4-20 mA. Any HART-communicator device can be connected to Transmitter SSS via standard HART-connector for readout gas concentration values, threshold changing, zero set-up and sensitivity calibration in a field conditions.

Universal Gas Transducer PGU consist of either catalytic electrochemical, infrared or photoionization replaceable sensors. PGU has integrated flash memory with adjustable settings, which are read automatically when connected to SSS Transmitter. Communication with Transmitter SSS is carried out by means of digital output RS-485. PGU sensor is fitted providing the additional protection from dust and high ambient humidity.

Transmitters SSS body is made from either stainless steel SS316 mark or Aluminum and has explosion proof protection and intrinsically safe barrier level.

SIL-2



Areas of Use	Feature and benefits
<ul style="list-style-type: none"> » Drilling and production » Refineries, bulk terminals and tank farms » Compressor stations and pipeline facility » Petrochemical, paint and fertilizer plants » Fuel loading facilities » Transportation facilities » Residential areas 	<ul style="list-style-type: none"> » 3 Colour LED status indicator (normal, fault, alarm) » Integral 48 Digit LCD display for easy viewing of detector status » Calibration Indicator » Non intrusive configuration of device » Quick and easy start up procedure (warm up time of device is less than 15 sec.) » Remote sensor option » Viewing of last 30 min. historical trend on display » Continuous self checking to ensure stable full functionality at all times » Display: <ul style="list-style-type: none"> -Gas Type -Threshold level -Measuring units -Reading history of last 30 mins with self-illuminating backlight.

4 Sensing Options

Electrochemical

Electrochemical sensors are used for detecting a wide range of toxic gases and oxygen. Fast response time and high reliability and operating life of the sensor makes it an excellent choice for detecting toxic gases in atmosphere.

Catalytic

For catalytic sensor combustible gases are available from C1 to C12 upon request as well as Hydrogen. PGU-C possesses long term stability and has proven to be extremely reliable in the harshest environments.

Infrared

Based on multi beam dual compensated non focusing infrared absorption. Optical performance allows for operation of sensor up to 75% obscuration, includes heated optics and dirty optics warning. Temperature compensation is inbuilt for optimum operation.

Photoionization

Based in the photoionization principle, PGU-P is a great selection for monitoring VOC's in the environment. Highly accurate and reliable. The sensor is not affected by high humidity.



SSS-903 GAS DETECTOR



Dual Sensor Arrangement

SSS-903, possesses the capability to connect 2 sensors simultaneously, enabling you to monitor the surrounding environment with different sensing methods integrated into one detector.

The SSS-903 also is capable of having remote sensor installation, giving the operator the ability to monitor environments as far as 500 meters away from the transmitter in hard to reach locations.

4 in 1

Unlike other manufacturers SSS-903 comes as standard with all the necessary outputs. This means no hidden costs, for the customer. This allows for greater versatility of the device also, since all the outputs are there the device is compatible with any system which it will be used with. Standard outputs will include 4-20mA, RS-485, Relays, HART.

Specification:

Voltage Supply: 24 VDC (18-32 VDC)

Power Consumption: <4W (Standby)
<6W (Alarm)
<12W (Heater ON)

Outputs:

- 4-20mA
- RS-485 (Modbus)
- HART 7.0
- Relay (AL1, AL2, Fault)

Sensor Types:

- Infrared,
- Electrochemical
- Photoionization
- Thermo-catalytic

Operational Characteristics:

Operating Temperature -40°C to +75°C

Humidity Range 0-95% RH

Ingress Protection IP66/IP67

Display and Indication:

- 3 colour LED status indicator
- Gas type
- Gas range
- Threshold level
- Diagram of last 30 min. operation
- Dual sensor option includes split screen for simultaneous viewing

Ex Marking: Ex d (ib) IIB+H2 T6 GB

SIL Rating: SIL-2

Repeatability: +/- 2% FS

Zero Drift: < 2% FS per year

Mechanical Characteristics

Material Stainless Steel (SS316)/ Aluminium

Cable Entry 2 x 3/4 NPT as standard (other options on request)

Weight Aluminum - 2.1 kg
Stainless Steel - 5.2 kg

Warranty 5 years

Dimensions

i) SSS Transmitter

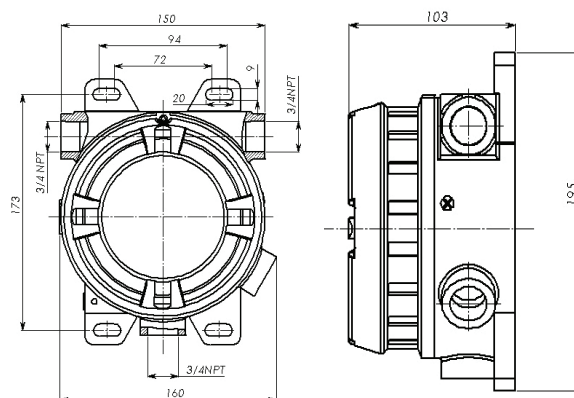

ii) Plug-in universal gas transducer PGU

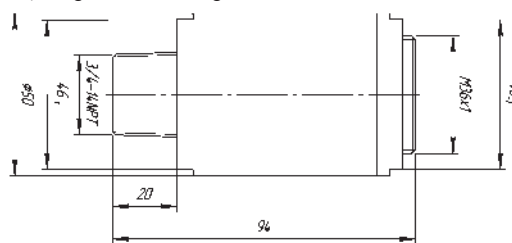

Certification:



SIL-2 (IEC 61508)
Class I, Division 1
Groups B, C & D



Ex d (ia) IIB+H2 T6
-40C to +75C
IP66



Ex d (ib) IIC T4
-40C to +85C
IP66



Controlled Gases

Transducer's type	Gas	Gas formula	Detected component measuring range	Accuracy	Response time
Plug-in universal gas transducer Optic Infrared PGU-IR	Methane	CH ₄	(0 - 100) % LEL	± 2% full Scale	T50 < 3 seconds T90 < 7 seconds
	Ethylene	C ₂ H ₄			
	Hexane	C ₆ H ₁₄			
	Butane	C ₄ H ₁₀			
	Isobutane	C ₄ H ₁₀			
	Ethane	C ₂ H ₆			
	Cyclopentane	C ₅ H ₁₀			
	Propylene	C ₃ H ₆			
	Methanol	CH ₃ OH			
	Propane	C ₃ H ₈			
	Pentane	C ₅ H ₁₂			
	Heptane	C ₇ H ₁₆			
Octane	C ₈ H ₁₈				
Plug-in universal gas transducers Photoionized PGU-P	Isobutylene	C ₄ H ₈	(0- 20) ppm (0- 200) ppm (0- 2000) ppm	± 2% full scale	T90 < 5 seconds
	Benzol	C ₆ H ₆	(0-100) ppm (0- 1 000) ppm (0- 1 0000) ppm		
	Ethylene	C ₂ H ₄	(0- 20) ppm (0- 2000) ppm		
	Methyl Mercaptan	CH ₃ SH	(0- 100) ppm Other ranges per request	± 2% full scale	T90 < 5 seconds
	All gases with ionization poten Hol <1 0.6 eV Gas Ionization Potentials see at Annexure 1.				
Plug-in universal gas transducers Electrochemical PGU-E	Hydrogen	H ₂	(0- 4) %val. (1 00% LEL) (0-100) ppm (0-1)%	± 2% full scale	T50 < 10 seconds T90 < 15 seconds
	Oxygen	O ₂	(0- 30) % vol.	± 2% full scale	T50 < 10 seconds T90 < 15 seconds
	Carbon monoxide	CO	(0-100) pp (0-500) ppm (0- 1 000) ppm	± 2% full scale	T50 < 10 seconds T90 < 15 seconds
	Hydrogen sulfide	H ₂ S	{0- 20) ppm (0 -50) ppm {0-100) ppm	± 2% full scale	T50 < 10 seconds T90 < 15 seconds
	Methanol	CH ₃ OH	{0- 100) ppm	± 2% full scale	T50 < 10 seconds T90 < 15 seconds
	Chlorine	Cl ₂	{0- 20) ppm	± 2% full scale	T50 < 10 seconds T90 < 15 seconds
Plug-in universal gas transducers Catalytic PGU-C	Methane	CH ₄	0 - 100% LEL	± 2% full scale	T50 < 10 seconds T90 < 15 seconds
	Propane	C ₃ H ₈	0 - 100% LEL	± 2% full scale	T50 < 10 seconds T90 < 15 seconds
	Hexane	C ₆ H ₁₄	0 - 100% LEL	± 2% full scale	T50 < 10 seconds T90 < 15 seconds
	Acrylonitrile	C ₃ H ₃ N	0 -100% LEL	± 2% full scale	T50 < 10 seconds T90 < 15 seconds
	Hydrogen	H ₂	0-100 ppm	± 2% full scale	T50 < 10 seconds T90 < 15 seconds

*The gases mentioned in the above table is only a representative sample, for any gases or ranges not mentioned in the above table please contact a sales representative.